

Performance limits of assembling machines

A. Schmidt, G. Höhne

Keywords: high speed assembly, continuous motion assembly, performance limits, configuration

1 Introduction

The automatic assembly of mass-produced articles (**Figure 1**) is more than ever an important point for manufacturing industry. For the majority of these products it is characteristic that it concerns "one-way products", which are produced under high cost pressure.



Figure 1. Mass-produced articles

- Pharmaceutical- and cosmetic industry (6, 7, 9)
- Packaging industry (6)
- Electrical industry
- Medical technology (1, 4, 5)
- Automotive industry(8)

With the manufacturing of these products high demands are made nevertheless against the assembly quality. In particular the assembly accuracy is to call the purity requirements during the assembly and the integration of highly precise test processes with 100% an examination. By the rising need on the market of the maintenance and communication electronics in the future also products of this range (e.g. mobile telephones) will rank among the product spectrum for the high speed assembly. With the increase of the product complexity also the requirements will particularly rise at assembly machines in the high speed assembly. In addition belong: larger number of the parts which can be assembled, different types of the parts (plastic -, metal -, rubber -, glass parts), functional test, manufacturing.

At present the majority of assembly machines are intermittent motion machines, most of them rotary assembly machines (**Figure 2**). In intermittent transfer the workstations' position is fixed. Parts are moved with an intermittent or discontinuous motion between the stations. All parts are moved at the same time, they have to accelerated and decelerated. This allows a maximum machine rate from up to 200 parts/ min.





		motion principle	
		intermittent	continuous
motion track	circle	 <p>market share: ca. 70% present performance limit: 200 parts/ min</p>	 <p>market share: ca. 3% present performance limit: 1000 parts/ min</p>
	line	 <p>market share: ca. 20% present performance limit: 100 parts/ min</p>	 <p>market share: ca. 1% present performance limit: ≥ 200 parts/ min</p>

Figure 2 .Assembly systems

Thereby large masses (top plate with carriers) must be accelerated and decelerated in each clock cycle, which leads to the limitation of the dynamics of the total machine.

Similar courses of motion the tools and handlings carry out, whereby necessary high accelerations for large masses the dynamics limit. Due to the masses and the necessary space requirement for tools and workpiece carriers, the number of stations is limited. The machine rate is determined by the work station with the largest time requirement.

In continuous motion, parts are indexed continuously at constant speed. As a result, the work head must also move during the processing to keep up with the moving parts. The advantage is that the assembled product is kept moving at a steady speed. Therefore there are no acceleration/ deceleration problems and the maximum machine output reached up to 500- 1000 parts /min (**Figure 2**).

In the majority of present applications vertical tool motions are used. The movement introduction of the tools is made by rack-firm cams, which are scanned by the tools rotating with the assembly tower. For rotations of the tools a pinion, which is fixed connected with the tool, is in interference with one at the assembly tower installed gear rim.

For both systems, intermitted and continuous motion, are two typical motion tracks, circle and line, in use. The highest potential for increase the machine output having continuous motion machines which used a circle motion track.

2 Objectives

One of the research objectives is to give a decision support to developers and users for the question: Which assembly concept should be selected for a special mass-produced article? The goal is it to find the optimal system configuration for a new assembly line in early stage of development.

Another point is the definition and demarcation from modules (e.g. chassis, work-holding transport, work heads, indexing mechanism) and interfaces between them. These modules should be for a multiplicity of assembly processes applicable and in case of a product change easily exchangeable.

A complete new installation from an assembly line with a product change is to be avoided. The adjustment of the assembly line by exchange of modules is made possible.

For the modules will be defined operating conditions and performance limits.

The research concentrates thereby on the development of assembly machines with continuous motion and high output.

3 Methods

The research starts with the analysis of known assembly processes and assembly machines at the market on the basis of size, form and number of parts as well as the types of joining operations and machine concepts. For selected machines at the market will be technical principles developed (**Figure 3**). These principles are helpful to define modules and interfaces. The results make the organization for a matrix possible.

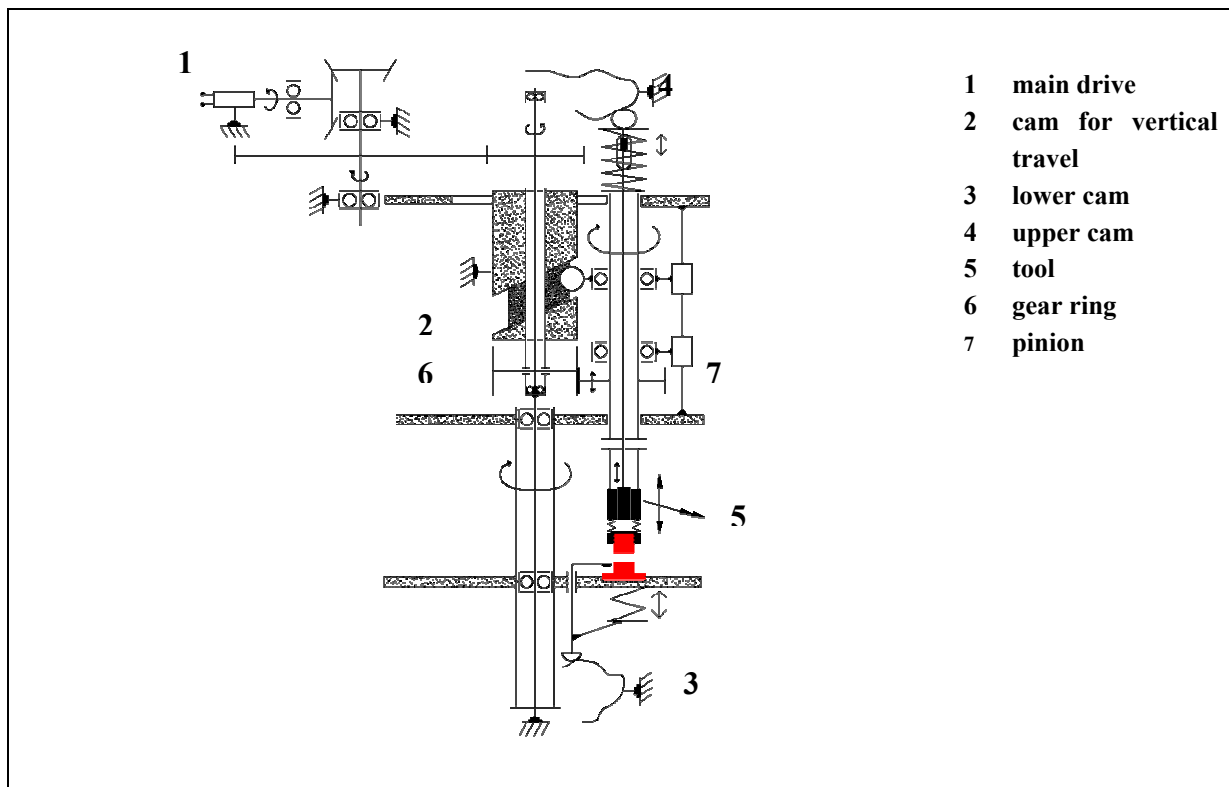

Figure 3. Technical principle

Based on recurrent operations, like feeding, transfer and fixture, modules with unified interfaces and flexible adaptability to the assembly objects can be developed.

In this process of development will execute the problem solving sequence in **Figure 4**. There are after the synthesis of functional structures and the design of solution principles two different paths for the design of machine components. First the compact configuration with a great extends of functional und structural integration. This path will be used in most of the assembling machines on the market presently. The present systems are conceived for the assembly of only one special product, the costs for a re-equipment are not profitable.

The current research has the development and dimensioning of modules and interfaces, which are applicable for different product groups and easily exchangeable, as a goal.

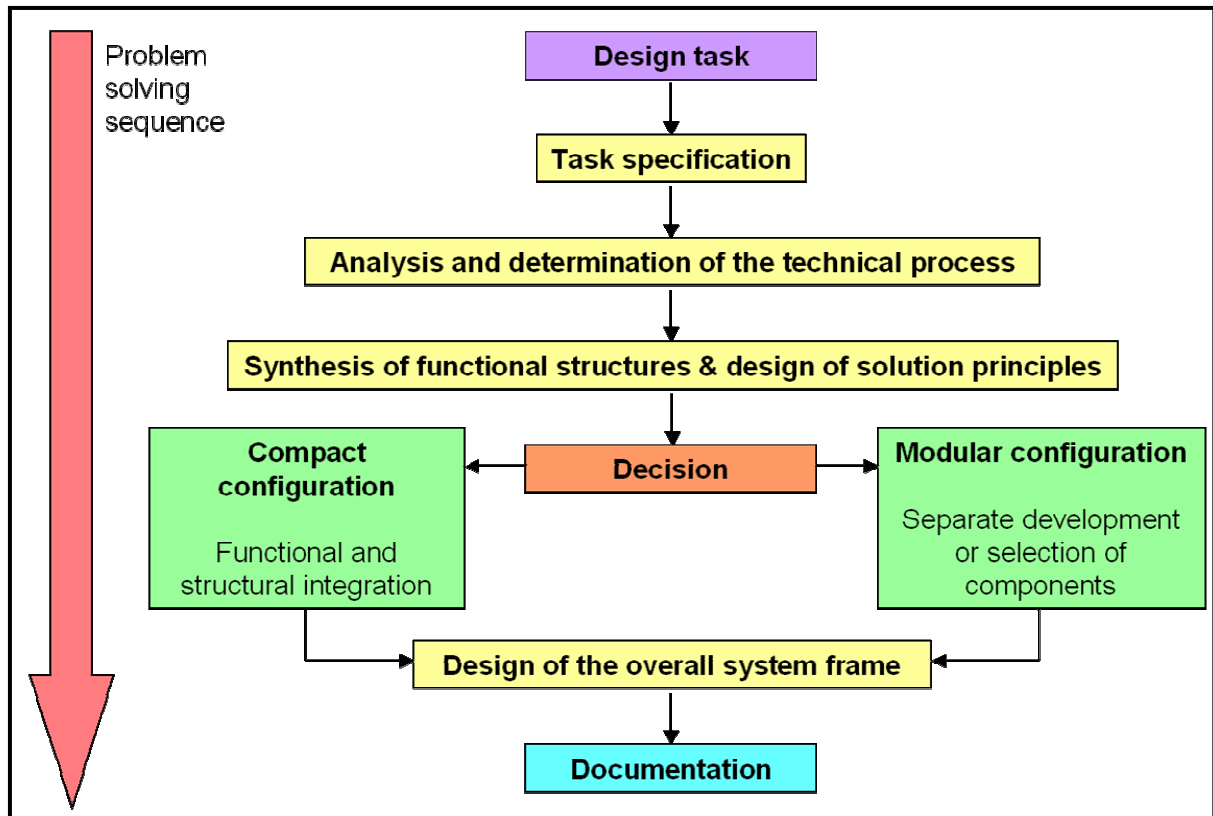

Figure 4. Problem solving sequence

In order to achieve a high efficiency the determination of kinematical and dynamic parameters for modules with computer-aided simulation e.g. MASP (program for Modelling and Analysis of Solution Principles [5]), multi-body systems, finite element method is necessary (**Figure 5**). The results of these simulations should be:

- higher dynamic stiffness
- lower mass
- long lifecycle of components and complete machine
- increase of maximum machine output
- determination of the performance limits from components and whose combination in complete machines
- reduction of the manufacturing and material costs

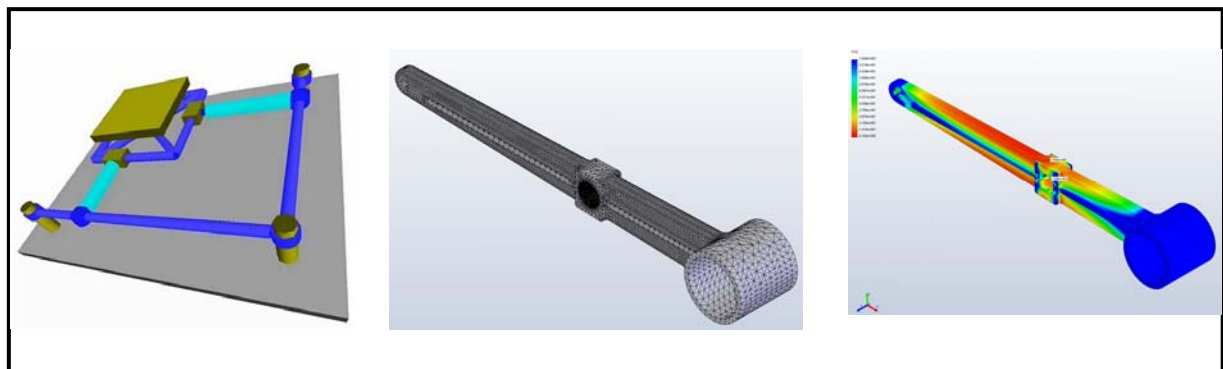

Figure 5. Computer-aided simulation from components and modules

The selection of the modules for an assembly requirement is a sense-making process with different criteria. In this process the performance parameters of the modules provide a basis for the optimal configuration of the assembly system and enable a maximum utilisation for the technical solutions up to their performance limits.

4 Results

One of the results will be the development of a configuration matrix with modular components (e.g. assembly chassis, transfer devices, work-holding fixtures, indexing system) of assembly machines (**Figure 6**). From this matrix the designer can choose modules for the specific requirement. These modules can be present also as parametric 3D-CAD data and support the designer with the development of the assembly system. An important influence for the selection of components has the parameters of the parts like size, mass, geometry. With these well-known parameters it should be possible for the developer to combine modules from the configuration matrix as from a construction kit.



Modules		assembly chassis	transfer devices	work-holding fixtures	indexing system
Parameters of parts	classification					
Number	2 3 4 ⋮					
size	e.g. 5 - 10 mm 11 - 30 mm					
mass	5 - 20g 21 - 50g ⋮					
geometry	cylindrical block cone ⋮					
material	metal plastics ⋮					
⋮						

Figure 6. Concept of a configuration matrix

Another point is to lay down guidelines for dimensioning and structuring of these components. In addition the results of the computer simulation are used. Supplementing a rough cost estimation is to be possible on the basis the given parameters. The design process for assembly machines is described as a computer assisted configuration process under use of parametric modules specifications. Thus a support for a customized configuration is already given in the offer and planning phase.

5 Conclusions

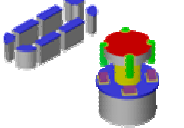
The presentation places a concept to the development and design for automatic assembly machines with continuous motion.

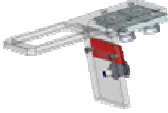
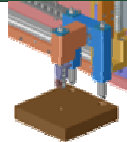
There are no absolute performance limits, the limits are determined by different physical parameters e.g. masses of the assembly parts, velocity of transport, duration of the assembly processes.

At the end the developer should received answers on the question “Where are the performance limits for the different types of automatic assembly machines and which concept is the optimal choice for a special product?”

The goal is it to find the optimal system configuration for a new assembly line in early stage of development. By the exchange from modules in case of changing the assembly product the changeover times will be explicit reduced and a clear lowering of production costs is attainable.

References

- [1] Riley, Frank J., “Assembly automation: a management handbook”, 2nd ed., Industrial Press Inc., 1996
- [2] Lotter, Bruno, “Wirtschaftliche Montage, ein Handbuch für Elektrogeräte u. Feinwerktechnik, VDI-Verlag, 1992
- [3] Shimon Y. Nof, Wilbert E. Wilhelm and Hans Jürgen Warnecke, “Industrial assembly”, Chapman & Hall, 1997
- [4] Hesse, Stefan, “Montagemaschinen: Grundlagen und Prinzipien in Aufbau, Funktion, Antrieb und Steuerung montierender Maschinen“, Vogel- Verlag, 1993
- [5] Brix, T., „Multi- stage modeling in the early phases of design”, ICED 03

Andreas Schmidt
Technische Universität Ilmenau
FG Konstruktionstechnik
Postfach 10 05 65
98684 Ilmenau, Germany
Tel.: +493677 69 50 79
E-Mail: andreas.schmidt@tu-ilmenau.de